

## Superchute® Chain Adjustment Procedure Using Come-Alongs

### Overview

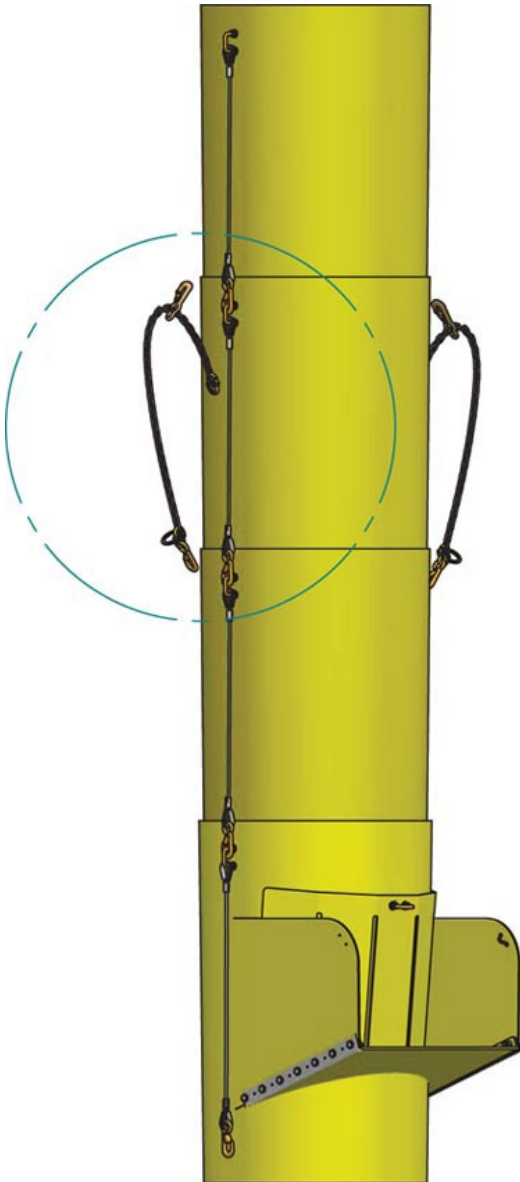

Step 1: Attach a pair of adjustable chains to 2 suspended regular sections - one chain per side.

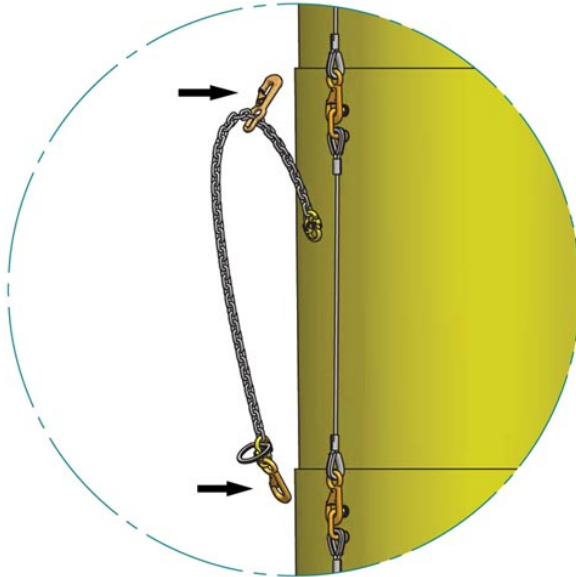

Step 2: This is how the installed chain should look. The ring on the chain kit will be used in the next step.

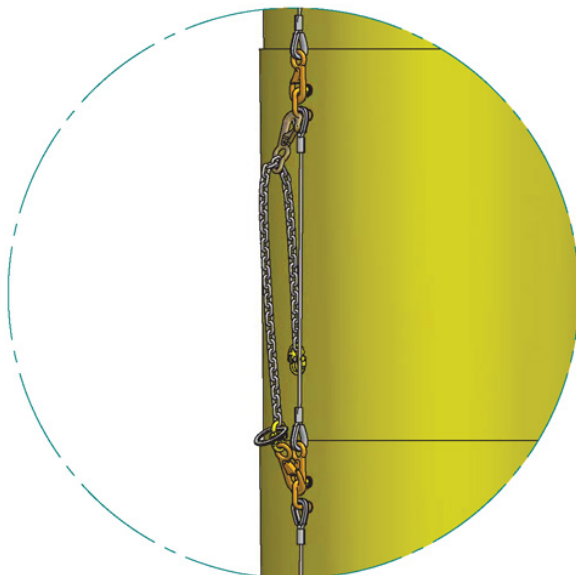

Step 3: Attach a Come-Along to the ring on the chain kit and to the U-bolt of the section above. Repeat.

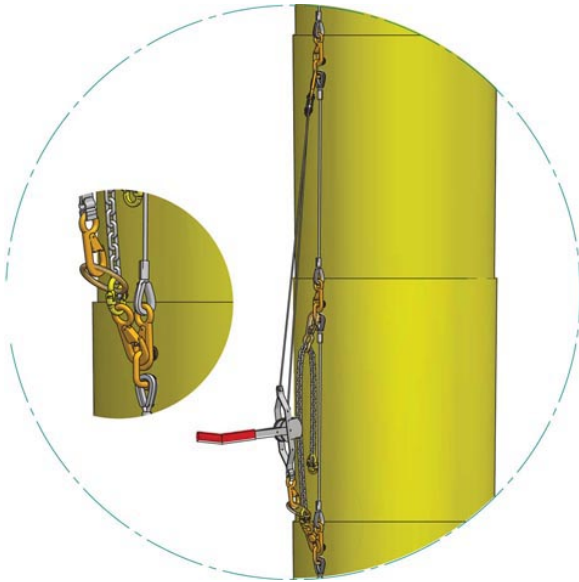

Step 4: Tension the Come-Alongs in order to nest the sections. Shorten the chain length.

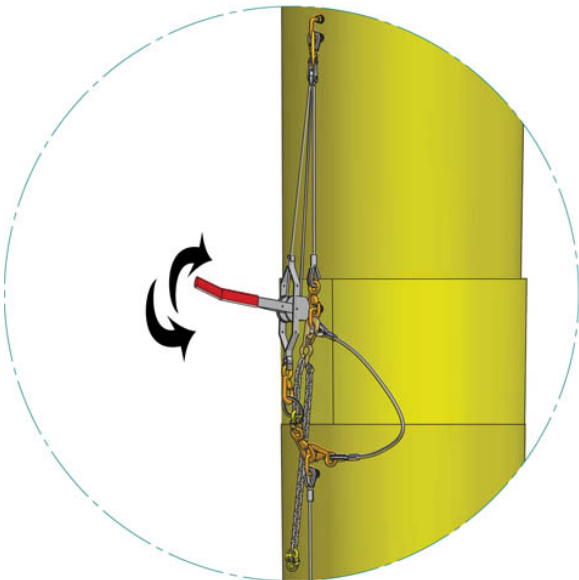

Step 5: Slacken & remove the come alongs.

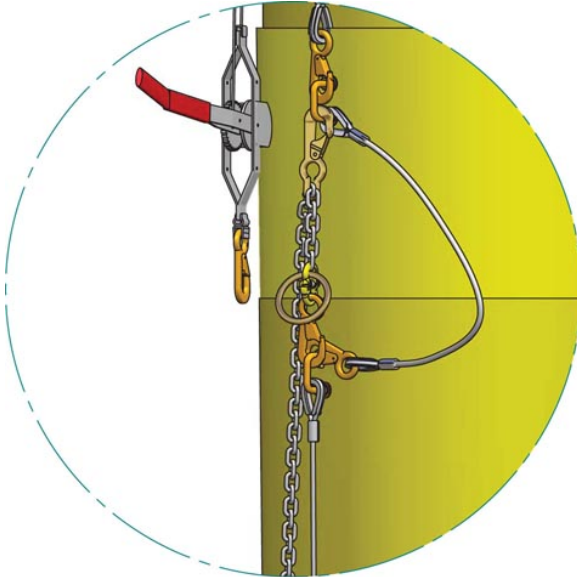

Step 6: The shortening of the section is complete.

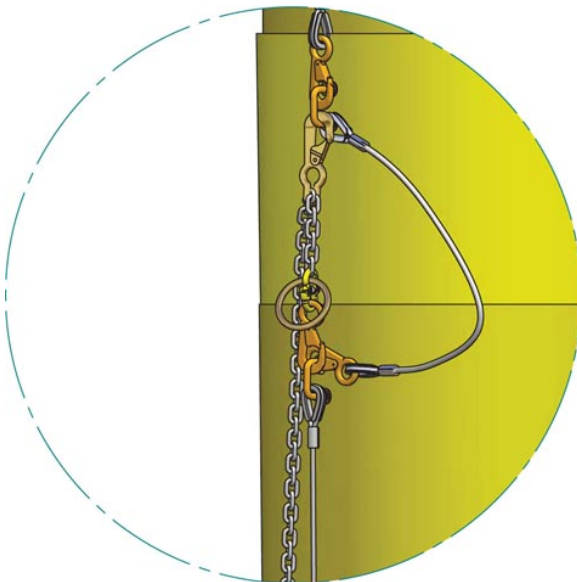

The chain locks in the keyhole notches when pressure is applied.

