

SC-2000-cb with Electric Fishpole Adapter Installation Procedure

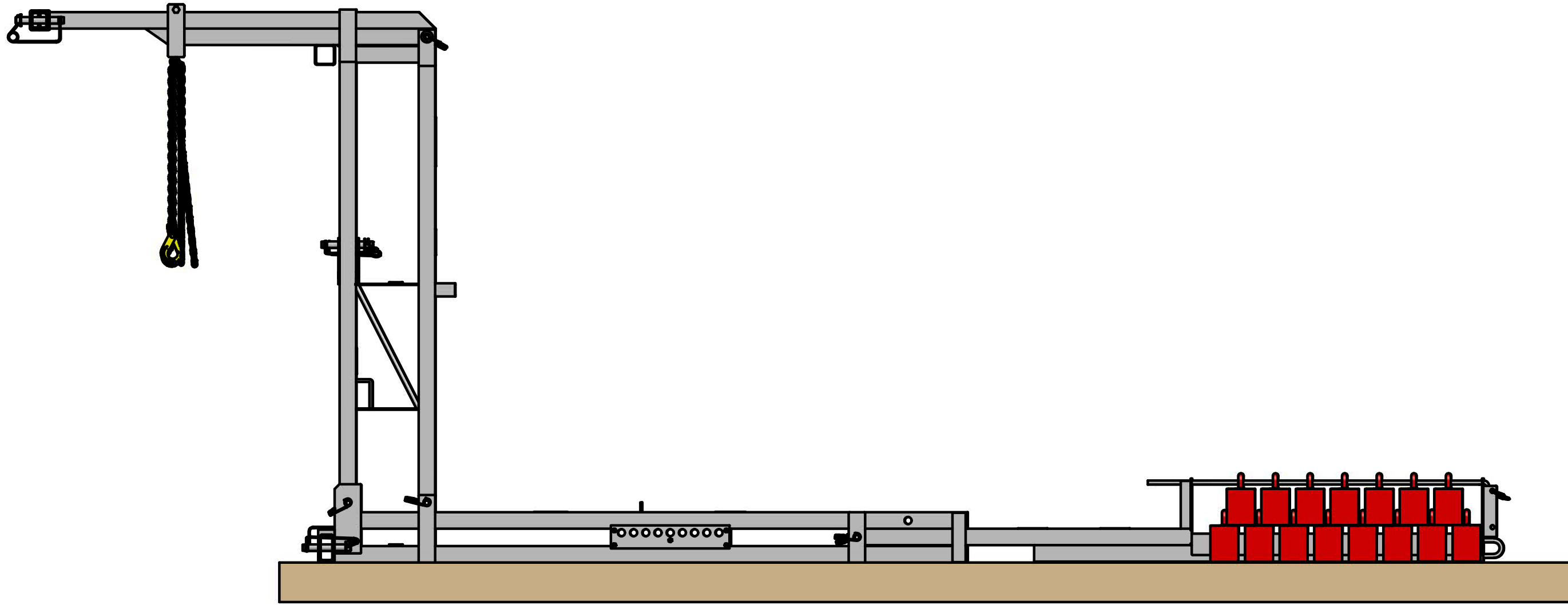

Step 1. Assemble the Suspension Frame per the instructions in the Chute Hoist Installation Manual

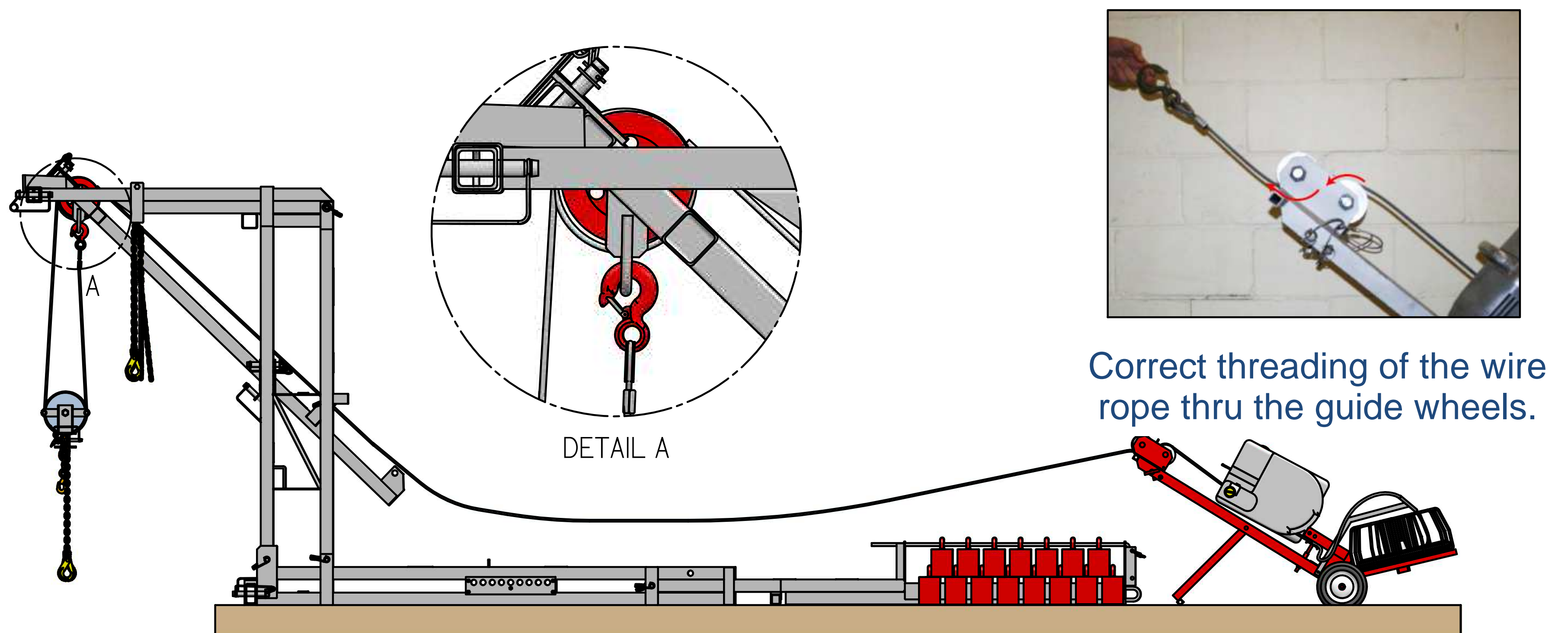

Step 2. Install the Fishpole on the frame as shown above

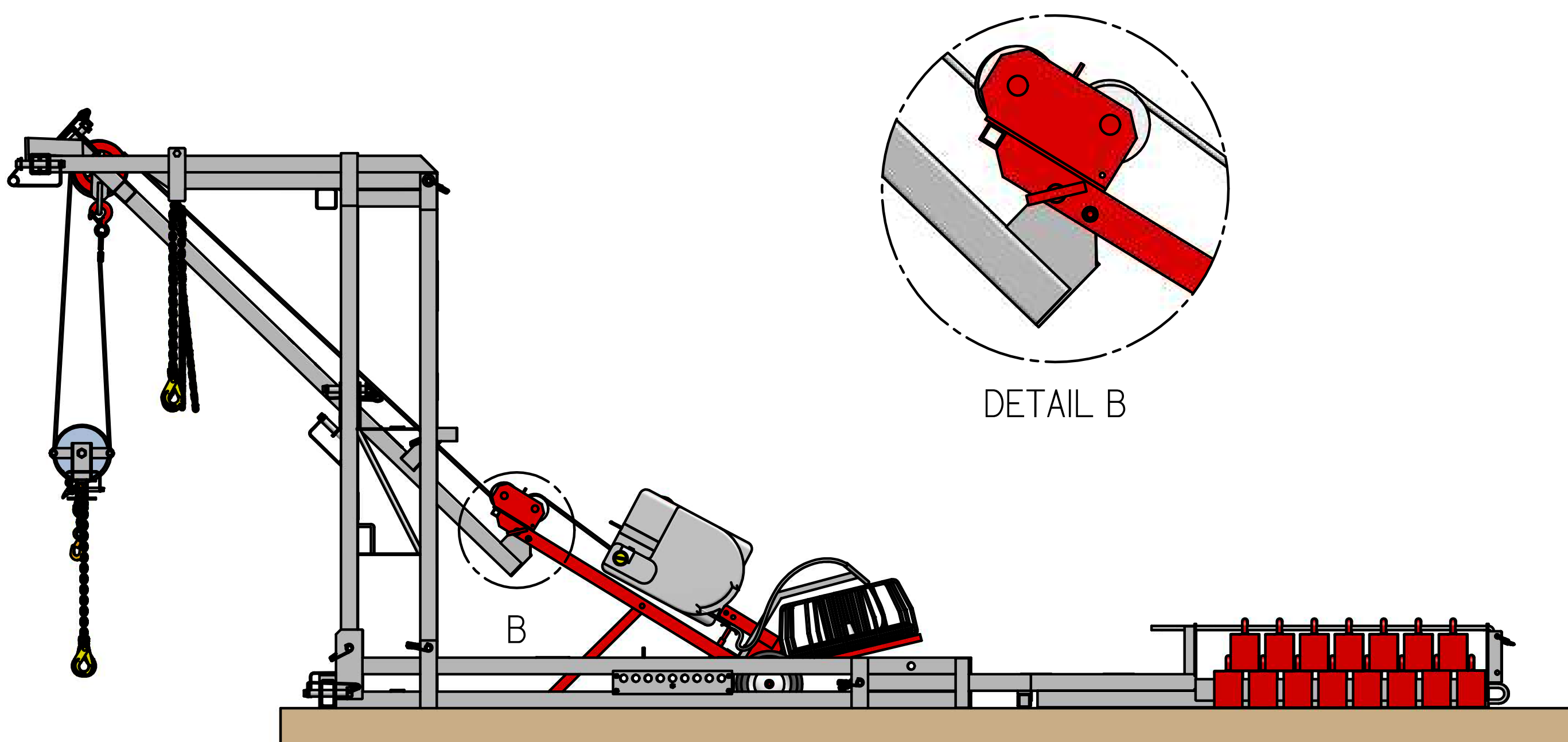

Step 3. Roll the EFA into position and pin the EFA to the butt of the Fishpole. Use the larger of the 2 pins. The large pin matches the pin diameter found on the Tractel **T516** manual winch box (the small pin matches the pin diameter of the Tractel **T508** manual winch box).



CUSTOMER	Sancton Access Inc
PROJECT	PC3 Installation
DRAWN BY	Lorin Spevack, B.Mech. Engineering
DATE	February 01, 2019
REV	Q-106XXX-1-A